

X300SD Amphibious Excavator



High Efficiency, Low Fuel Consumption, Stable Performance, Low Ground Pressure.
Powerful high-efficiency engine with low fuel consumption and high reliability.

High torque travelling pontoon devices ensure strong driving force, low ground pressure and high maneuverability. A humanized cab with air conditioning, USB compatible audio and great all-round visibility ensures a comfortable work environment.

TECHNICAL PARAMETERS

Specifications	
Operating Weight	30,000 kg
Bucket Capacity	0.9 m ³
Boom Length	5,680 mm
Arm Length	2,912 mm
Chains	3
Engine	
Model	Isuzu 6BG1
Type	Inter-Cooled Turbo
Power	114 kw / 2,100 rpm
Max. Torque	629 Nm / 1,600 rpm
No. of Cylinders	6
Displacement	6.49 L

Hydraulic System	
Main Pump	
Type	Variable Plunger Pump
Max. Displacement	2 * 107 cm ³ / r
Working Pressure	32 MPa
Hydraulic Motor	
Slew Motor	Fixed Plunger
Travel Motor	Variable Plunger
Oil Tank Capacity	
Fuel Tank	376 L
Hydraulic Tank	219 L

TECHNICAL PARAMETERS

Performance	
Slew Speed	11 rpm
Min. Slew Radius	6,550 mm
Max. Travel Speed, H / L	3.29 km/h • 2.17 km/h
Gradeability	35°
Tracktive Effort	382.4 kN
Max. Digging Force, Bucket	122.85 kN
Max. Digging Force, Arm	97.64 kN
Ground Pressure	0.14 kg / cm ²

Item	Standard (mm)
A. Length of Pontoon	8,285 mm
B. Platform Ground Clearance	1,936 mm
C. Overall Height	3,759 mm
D. Boom Transport Ht.	3,379 mm
E. Overall Length	10,747 mm
F. Rear Swing Radius	2,800 mm
G. Track Gauge	3,950 mm
H. Overall Width	4,600 mm
I. Width of Pontoon	1,800 mm
J. Min. Ground Clearance	1,126 mm
K. Height of Pontoon	1,652 mm
L. Width, Upper Structure	2,622 mm
M. Ground Length	5,088 mm

Item	Standard (mm)
a. Max. Digging Reach	10,186 mm
b. Max. Digging Reach on Ground	10,163 mm
c. Max. Digging Depth	3,201 mm
d. Max. Vertical Digging Depth	10,163 mm
e. Max. Digging Height	7,027 mm
f. Max. Dumping Height	6,928 mm
g. Min. Front Slewing Radius	6,550 mm

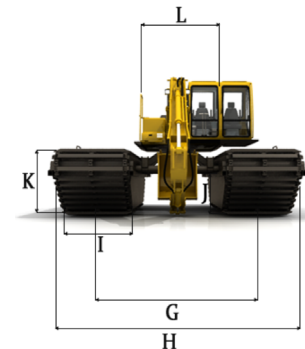
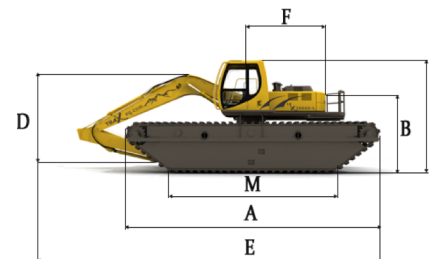
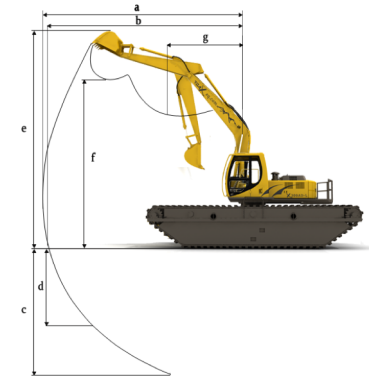

The manufacturer reserves the right to change the technical specifications without notice.